

Richard D. Plecker
 RICHARD PLECKER
 ENVIRONMENTAL UTILITIES DIRECTOR

NOTE: ALL PIPING INCLUDING BRASS TO BE 8 MIL POLY SEALED.
 WRAP BRASS SPOOLS WITH RECYCLED WATER ID TAPE. TAPE
 TO BE PLACED OUTSIDE OF POLY SEAL.
 INSTALL RECYCLED WATER TAG TO VALVE STEM.

BLOWOFFS OUTSIDE OF PAVED AREAS SHALL BE A MINIMUM OF
 6" ABOVE GRADE AND MARKED WITH A CARSONITE MARKER.

	ENVIRONMENTAL UTILITIES DEPARTMENT	
	RECYCLED WATER 2" INCH BLOWOFF ASSEMBLY (ALL BRASS)	
SCALE: NONE REVISED: JANUARY 2021 DRAWN BY: R. VAN NESS APPROVED BY: RICHARD PLECKER		RW-1

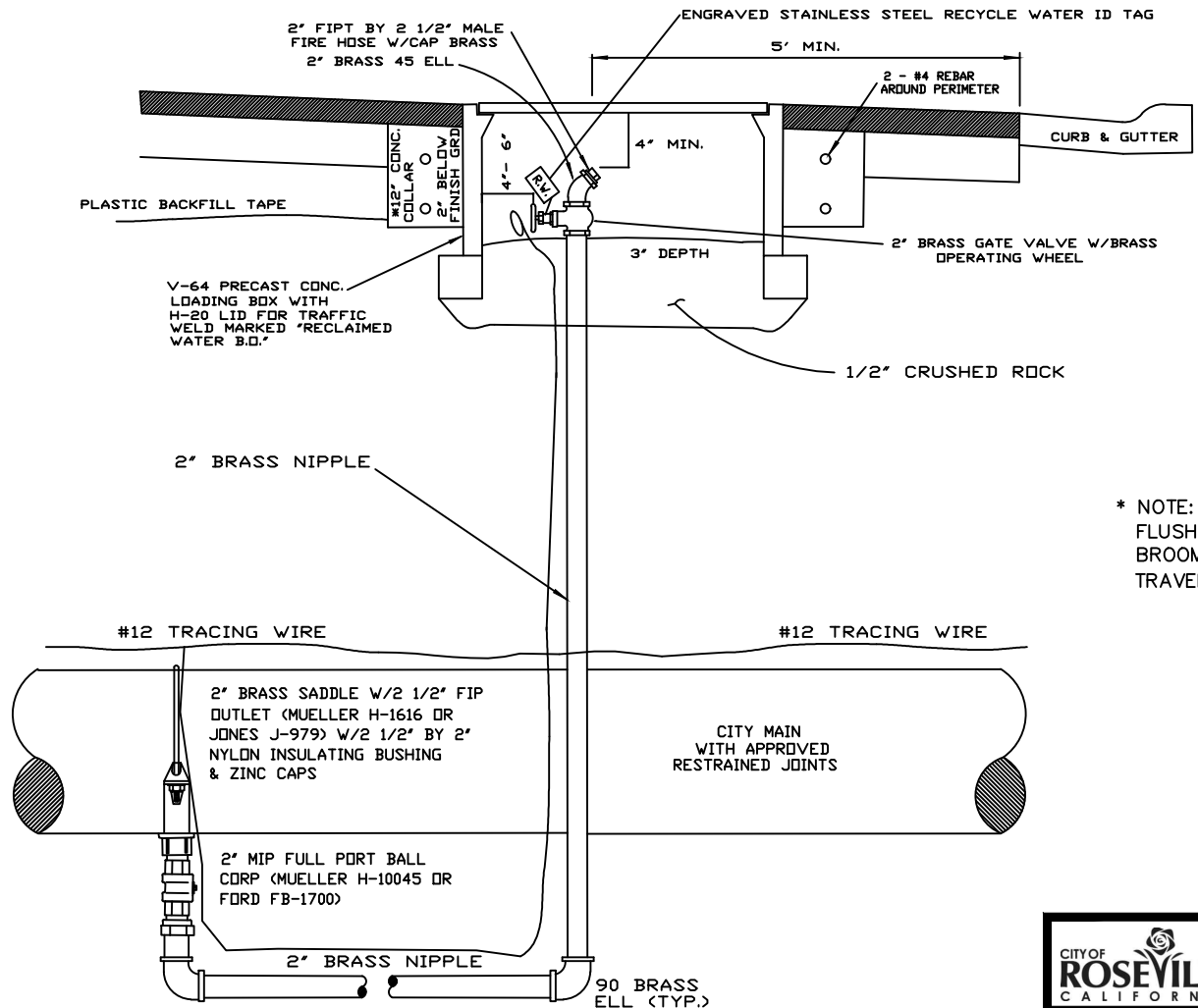

* NOTE: CONCRETE COLLAR MAY BE PLACED FLUSH TO FINISHED SURFACE WITH MEDIUM BROOM FINISH PERPENDICULAR TO VEHICLE TRAVEL DIRECTION.

Richard D. Plecker
 RICHARD PLECKER
 ENVIRONMENTAL UTILITIES DIRECTOR

CITY OF ROSEVILLE
 CALIFORNIA
 ENVIRONMENTAL UTILITIES DEPARTMENT

RECYCLED WATER INLINE 2" BLOWOFF ASSEMBLY (ALL BRASS)

SCALE: NONE
 REVISED: JANUARY 2021
 DRAWN BY: R. VAN NESS
 APPROVED BY: RICHARD PLECKER

RW-2

NOTES: ALL PIPING INCLUDING BRASS TO BE 8 MIL POLY SEALED. WRAP BRASS WITH RECYCLED WATER ID TAPE. TAPE TO BE PLACED OUTSIDE OF POLY SEAL.
 INSTALL RECYCLED WATER TAG TO VALVE OPERATOR STEM.
 POUR (1) FOOT DEEP BY 6' WIDE CONCRETE COLLAR AROUND UTILITY BOX IF OUTSIDE PAVEMENT AREA.
 BLOWOFFS OUTSIDE OF PAVED AREAS SHALL BE A MINIMUM OF 6' ABOVE GRADE AND MARKED WITH A CARSONITE MARKER.

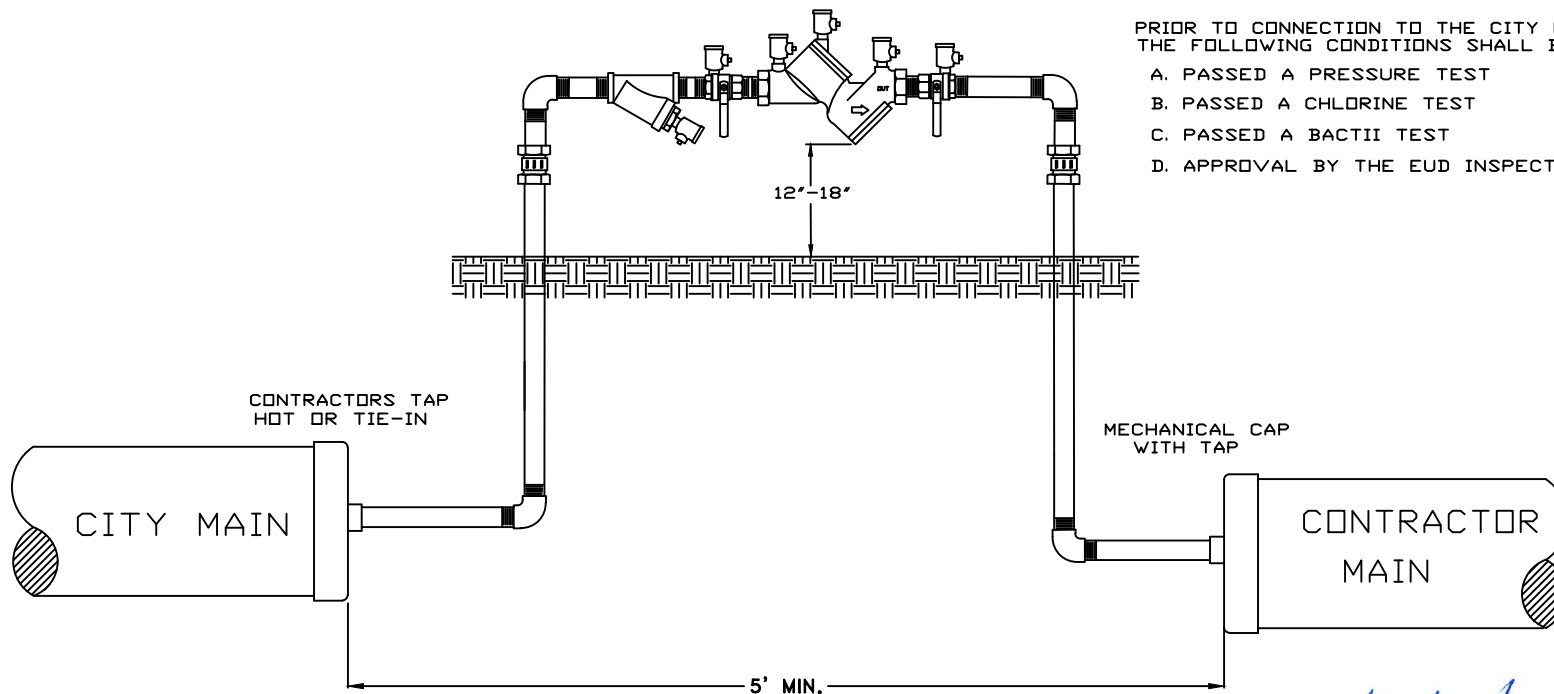

PRIOR TO CONNECTION TO THE CITY MAIN,
THE FOLLOWING CONDITIONS SHALL BE MET:

- A. PASSED A PRESSURE TEST
- B. PASSED A CHLORINE TEST
- C. PASSED A BACTII TEST
- D. APPROVAL BY THE EUD INSPECTOR

Richard D. Plecker

RICHARD PLECKER
ENVIRONMENTAL UTILITIES DIRECTOR

NOTES:

WATER SHALL ONLY BE DRAWN INTO THE CONTRACTORS MAIN THROUGH A CITY APPROVED RP TYPE BACKFLOW DEVICE WHICH HAS BEEN TESTED BY THE ENVIRONMENTAL UTILITIES DEPARTMENT.

FINAL SYSTEM COMPONENTS NECESSARY FOR TIE-IN SHALL BE PRE-CHLORINATED AND PRE-FLUSHED IN THE PRESENCE OF AN ENVIRONMENTAL UTILITIES DEPARTMENT INSPECTOR.

UPON COMPLETION OF THE CONDITIONS NOTED ABOVE AND WITH THE APPROVAL OF THE EUD INSPECTOR, CONNECTION TO THE CITY SYSTEM MAY BE MADE. THE EUD INSPECTOR SHALL BE NOTIFIED 48 HOURS PRIOR TO THE START OF WORK.



ENVIRONMENTAL UTILITIES
DEPARTMENT

RECYCLED WATER
CONSTRUCTION WATER

SCALE: NONE
REVISED: JANUARY 2016
DRAWN BY: R. VAN NESS
APPROVED BY: RICHARD PLECKER

RW-3

NOTES:

- NO WATER IS TO BE DRAWN THROUGH THE BACKFLOW DEVICE UNTIL IT HAS BEEN TESTED BY THE ENVIRONMENTAL UTILITIES DEPT.
- PIPE SHALL BE DUCTILE IRON.
- SPOOLS UPSTREAM & DOWNSTREAM OF METER SHALL BE 5X THE PIPE DIAMETER
- PIPE AND FITTINGS SHALL BE WRAPPED 8 MIL POLYETHYLENE
- USE CITY APPROVED RESTRAINED JOINTS OR FLANGED SPOOLS
- WATER METER SHALL BE PURCHASED THROUGH THE CITY. PURCHASE INCLUDES INSTALLATION.
- BOXES SHALL HAVE METAL LIDS MARKED "RECYCLED WATER" WITH 2" LETTERS

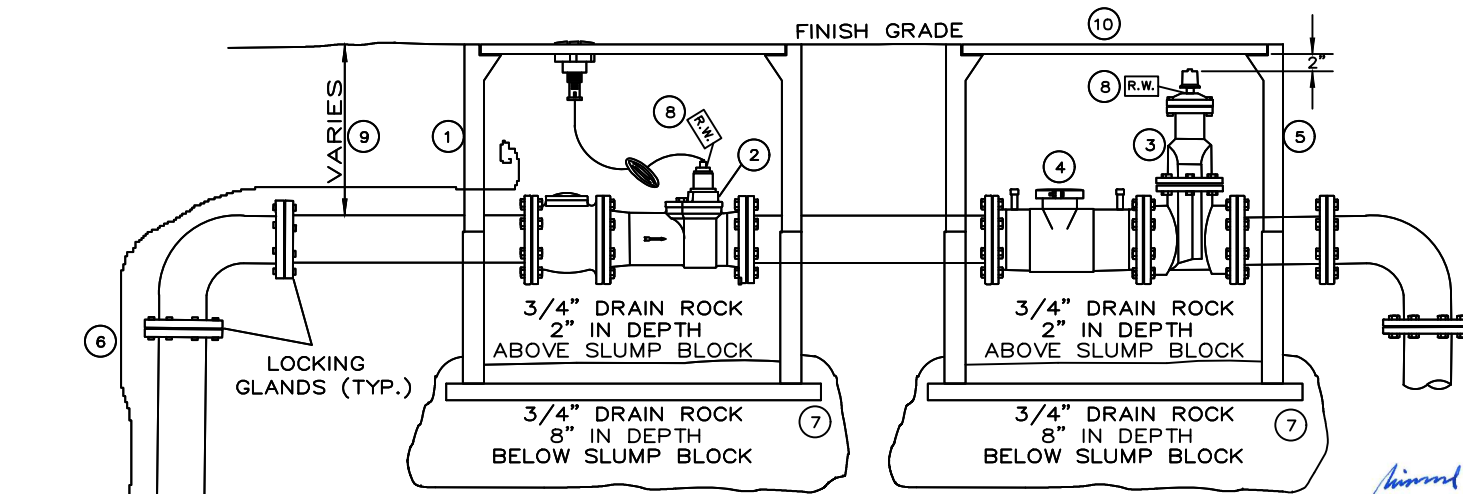

MATERIALS:

- 1) B48 BOX WITH 10" EXTENSION. MORTAR JOINTS INSIDE & OUT
- 2) METER WITH STRAINER (PURCHASED THROUGH CITY)
INSTALL IDLER SPOOL DURING INSTALLATION OF METER BOX.
- 3) RESILIENT SEAT GATE VALVE (NRS)
- 4) SINGLE CHECK BACKFLOW DEVICE, AMES 1000SS, (STAINLESS) OR AMERICAN FLOW CONTROL 2100 (EPOXY)
- 5) B48 BOX WITH 10" EXTENSION. MORTAR JOINTS INSIDE & OUT
- 6) CITY APPROVED TRACING WIRE
- 7) INSTALL CONCRETE BRICK (3" X 5") UNDER ENTIRE PERIMETER OF BOXES
- 8) ENGRAVED STAINLESS STEEL RECYCLED WATER ID TAG
- 9) 3"-6" PIPE SHALL BE 16" MIN. TO 20" MAX.
8" OR 10" PIPE SHALL BE 22" MIN. TO 26" MAX.
- 10) ENGRAVED STAINLESS STEEL ADDRESS TAG AFFIXED TO WATER METER LID.

RICHARD PLECKER
ENVIRONMENTAL UTILITIES DIRECTOR



ENVIRONMENTAL UTILITIES
DEPARTMENT

**RECYCLED WATER
3" & LARGER SERVICE**

SCALE: NONE
REVISED: JANUARY 2021
DRAWN BY: R. VAN NESS
APPROVED BY: RICHARD PLECKER

RW-4

NOTE:

BURIED PIPE AND FITTINGS SHALL BE WRAPPED WITH 8 MIL POLYETHYLENE OR APPROVED EQUAL.
BOXES SHALL HAVE METAL LIDS MARKED "RECYCLED WATER" WITH 2" LETTERS

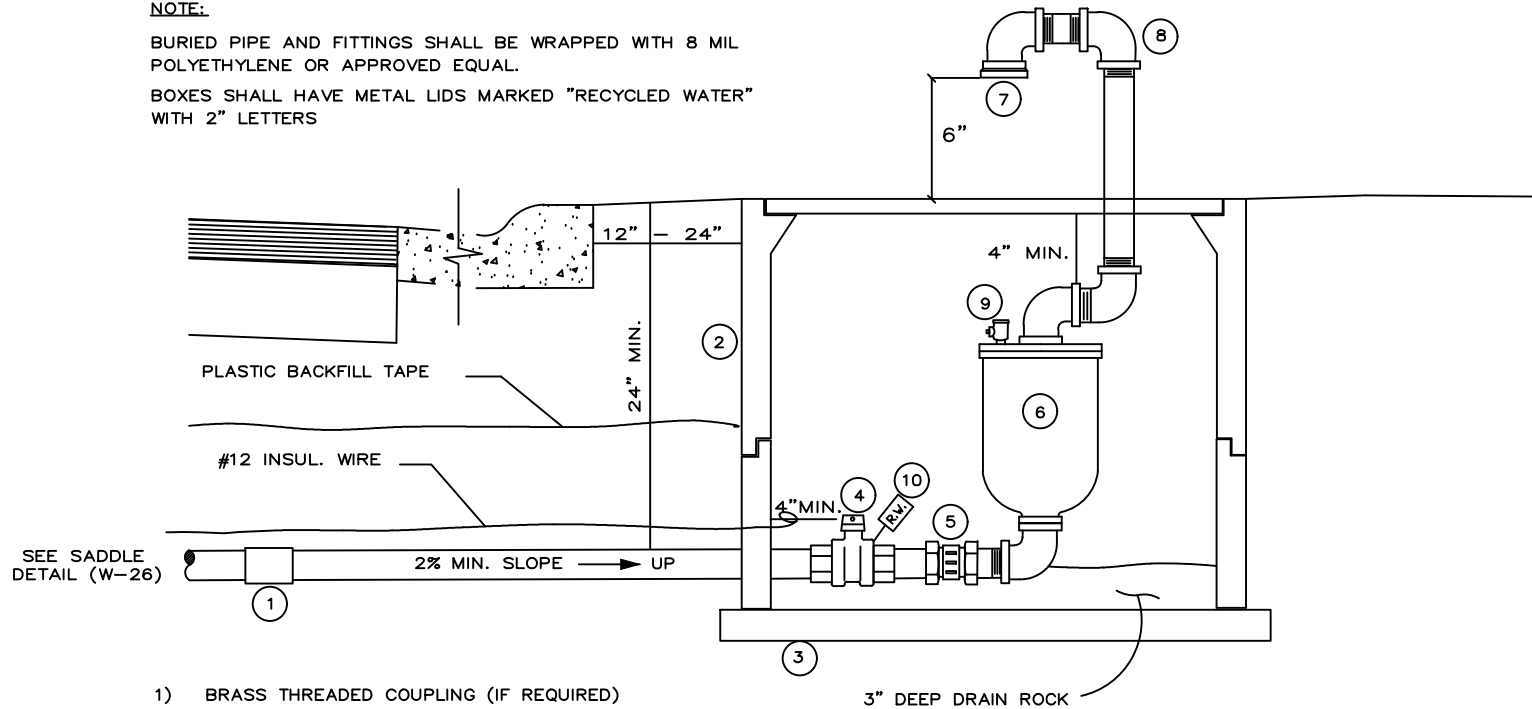

- 1) BRASS THREADED COUPLING (IF REQUIRED)
- 2) B-40 UTILITY BOX W/TRAFFIC COVER MARKED, "RECYCLED WATER ARV". IF EXTENSION IS REQ. MORTAR EXTENSION JOINT INSIDE & OUT.
- 3) CONCRETE BRICK (3"X5") UNDER ENTIRE PERIMETER OF UTILITY BOX.
- 4) CURB STOP
- 5) BRASS UNION
- 6) COMBINATION AIR / VACUUM VALVE CRISPIN UL-20, APCO 145C OR APPROVED EQUAL.
- 7) BRASS CAP WITH 9 DRILLED 1/16" HOLES OR APPROVED EQUAL.
- 8) USE GALVANIZED PIPE AND FITTINGS ABOVE GROUND
- 9) 1/4" TEST COCK
- 10) ENGRAVED STAINLESS STEEL RECYCLED WATER I.D. TAG

Richard D. Plecker

RICHARD PLECKER
ENVIRONMENTAL UTILITIES DIRECTOR

CITY OF
ROSEVILLE
CALIFORNIA

ENVIRONMENTAL UTILITIES
DEPARTMENT

**1" AND 2" AIR RELEASE
VALVE ASSEMBLY**

SCALE: NONE
REVISED: JANUARY 2021
DRAWN BY: R. VAN NESS
APPROVED BY: RICHARD PLECKER

RW-5

- 1) CONCRETE VALVE BOX (G-5 PER DETAIL W-16)
BOX LID SHALL BE MARKED "RECYCLED WATER"
- 2) 6" CONTINUOUS RISER (NOTCHED OVER
PIPE AT BASE)
- 3) CURB STOP (COMPRESSION X FIPT)
- 4) CONCRETE COLLAR (SEE DETAIL W-16)
- 5) METER SETTER WITH IDLER
- 6) N-16 UTILITY BOX OR APPROVED EQUAL FOR 3/4"
N-30 UTILITY BOX OR APPROVED EQUAL FOR 1"

- 7) METER (PURCHASED THROUGH CITY)
- 8) ENGRAVED STAINLESS STEEL RECYCLED WATER I.D. TAG
- 9) SCH. 40 PVC THROUGH PIPE EYE
- 10) METER SPUD
- 11) 18" BRASS NIPPLE WITH END CAP
- 12) INSTALL CONCRETE BLOCKING
(4" X 4" X 15 1/2")
UNDER ENTIRE PERIMETER OF BOXES
- 13) ENGRAVED STAINLESS STEEL ADDRESS TAG AFFIXED TO METER
BOX LID.

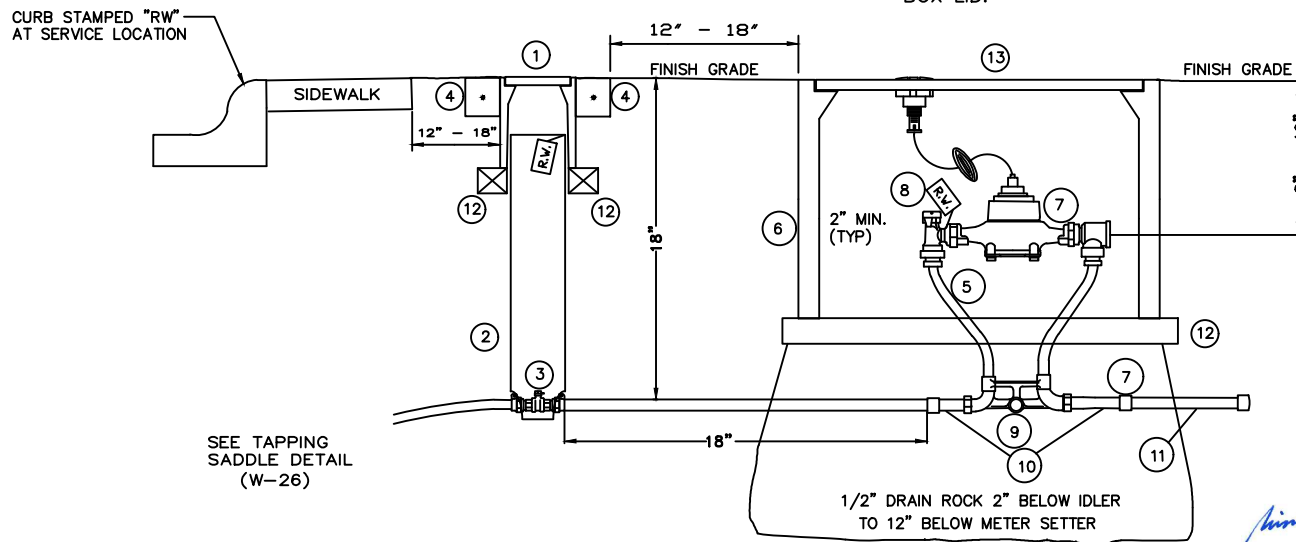

Richard D. Plecker

RICHARD PLECKER
ENVIRONMENTAL UTILITIES DIRECTOR

NOTES:

ALL FITTINGS AND PIPING SHALL BE BRASS BEGINNING AT THE CURB STOP

WATER METERS SHALL BE PURCHASED THROUGH THE CITY
PURCHASE INCLUDES INSTALLATION.

BURIED PIPE AND FITTINGS SHALL BE WRAPPED WITH 8 MIL
POLYETHYLENE OR APPROVED EQUAL.

BOXES SHALL HAVE METAL LIDS AND WILL BE MARKED
"RECYCLED WATER" WITH 2" LETTERS



ENVIRONMENTAL UTILITIES
DEPARTMENT

3/4" & 1"
SERVICE LINE

SCALE: NONE
REVISED: JANUARY 2021
DRAWN BY: R. VAN NESS
APPROVED BY: RICHARD PLECKER

RW-6

MATERIALS:

- 1) 3/4" COPPER SERVICE LINE - TYPE K
- 2) 6" DIA. SCHEDULE 40 RISER NOTCHED OVER PIPE AT BASE
- 3) CURB STOP
- 4) CHRISTY G-5 TRAFFIC BOX W/ ALL METAL LID WELD MARKED "RW"
- 5) 3/4" TO 1" REDUCER ALL BRASS
- 6) 4" LIGHT WELL STEEL PIPE BOLTED INTO BASE
- 7) 12" BY 12" BY 12" CONCRETE STABILITY SLAB
- 8) 1" BRASS BALL VALVE
- 9) HYDRANT STYLE BRASS VALVE
- 10) UNTHREADED BRASS NOZZLE
- 11) HANDLE OPERATOR WITH ENGRAVED STAINLESS STEEL RECYCLED WATER ID TAG ATTACHED.
- 12) ALUMINUM CAST BOX PAINTED WITH PURPLE WEATHER PROOF PAINT. STENCIL MARK "RECYCLED WATER DO NOT DRINK" ON MINIMUM OF (2) SIDES
- 13) LAY RECYCLED WATER ID TAPE ON TOP OF SERVICE
- 14) ENGRAVED STAINLESS STEEL RECYCLED WATER ID TAG.

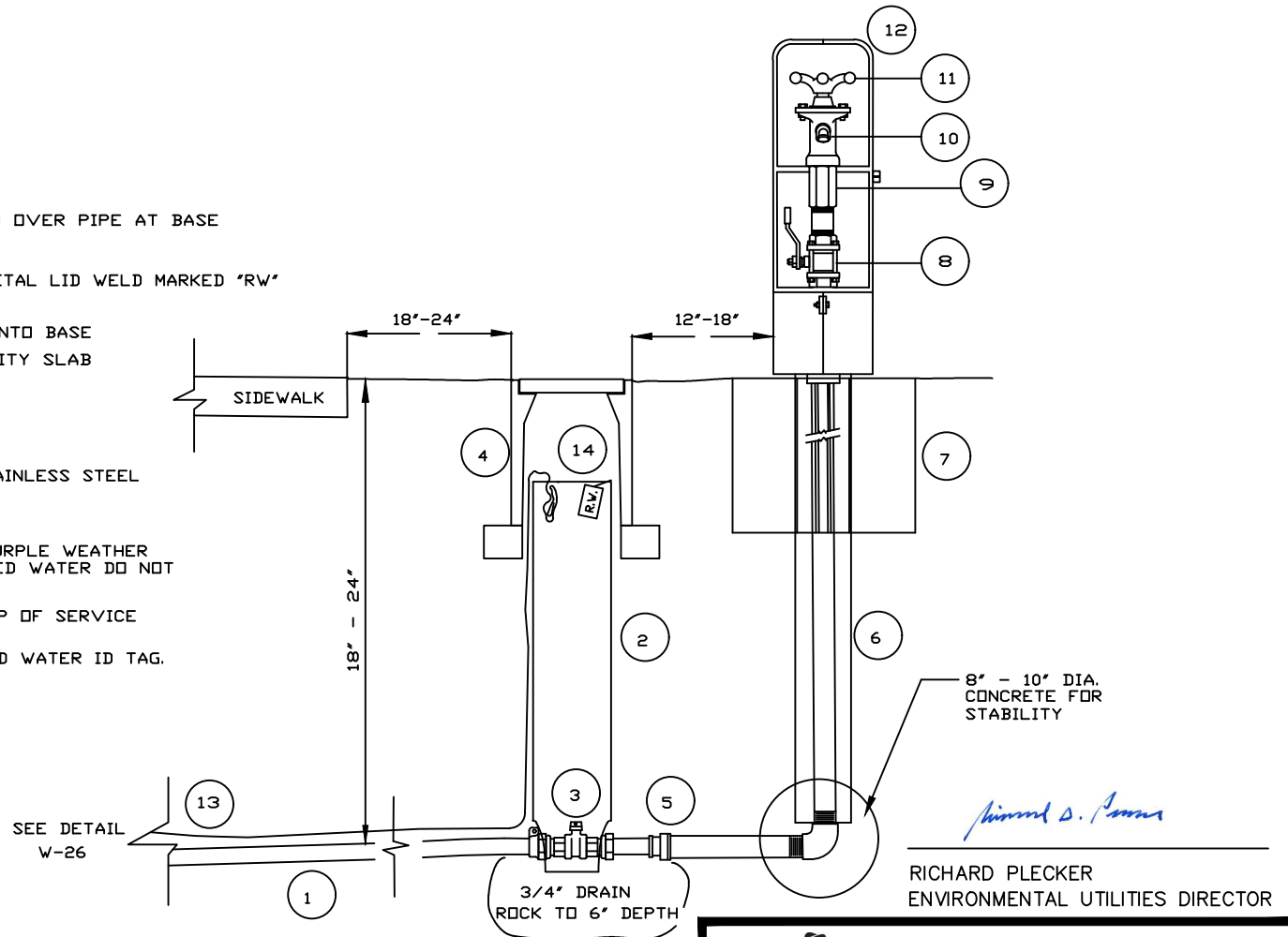

NOTES:

- INSTALL CONCRETE BRICK (3" X 5") UNDER ENTIRE PERIMETER OF THE BOX.
- ALL PIPING FROM REDUCER THROUGH TEST STATION TO BE 1" BRASS
- ALL FITTINGS TO BE BRASS

Richard D. Plecker
 RICHARD PLECKER
 ENVIRONMENTAL UTILITIES DIRECTOR

	ENVIRONMENTAL UTILITIES DEPARTMENT
	RECYCLED WATER #88-V ECLIPSE SAMPLING STATION FOR WARM CLIMATES
SCALE: NONE REVISED: JANUARY 2021 DRAWN BY: R. VAN NESS APPROVED BY: RICHARD PLECKER	RW-7

CURB STAMPED "RW"
AT SERVICE LOCATION

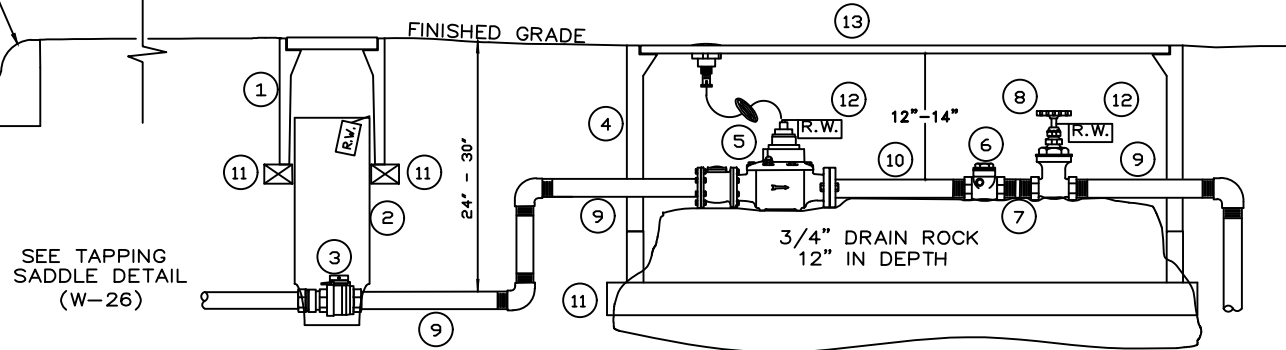

SEE TAPPING
SADDLE DETAIL
(W-26)

NOTES:

NO WATER SHALL BE DRAWN THROUGH THE BACKFLOW DEVICE UNTIL IT HAS BEEN TESTED BY THE ENVIRONMENTAL UTILITIES DEPT.

CONTRACTOR SHALL LAY 3/4" DRAIN ROCK TO 12" DEPTH UNDER CONCRETE BLOCKING AT METER

WATER METERS SHALL BE PURCHASED THROUGH THE CITY. PURCHASE INCLUDES INSTALLATION.

THERE SHALL BE NO FLOW ALTERING DEVICES 5X THE PIPE DIAMETER UPSTREAM AND DOWNSTREAM OF THE METER.

CURBSTOP SHALL BE BETWEEN 12" & 18" OF EASEMENT.

BURIED PIPE AND FITTINGS SHALL BE WRAPPED WITH 8 MIL POLYETHYLENE OR APPROVED EQUAL.

SINGLE CHECK BACKFLOWS: WATTS CVY (BRONZE), WATTS WCV -2 (BRASS W/RUBBER DISK SEALS) WATTS 806 (316 STAINLESS STL.), MATCO/NORCA MODEL 530 (BRONZE)

BOXES SHALL HAVE METAL LIDS MARKED "RECYCLED WATER" WITH 2" LETTERS.

Richard D. Plecker

RICHARD PLECKER
ENVIRONMENTAL UTILITIES DIRECTOR

- 1) G-5 VALVE BOX (PER DETAIL W-16)
- 2) 6" CONTINUOUS RISER (NOTCHED OVER PIPE AT BASE)
- 3) CURB STOP COMPRESSION X FIPT
- 4) B-48 UTILITY BOX W/ EXTENSION (MORTAR JOINTS INSIDE & OUT)
- 5) TURBO METER WITH STRAINER (PURCHASED THROUGH CITY). INSTALL IDLER SPOOL DURING INSTALLATION OF METER BOX.
- 6) SINGLE CHECK (SEE NOTES)

- 7) 3" BRASS NIPPLE
- 8) ALL BRASS GATE VALVE (FIPT X FIPT)
- 9) 12" BRASS NIPPLE
- 10) 6" BRASS NIPPLE
- 11) INSTALL CONCRETE BRICK (3" X 5") UNDER ENTIRE PERIMETER OF UTILITY BOXES
- 12) ENGRAVED STAINLESS STEEL RECYCLED WATER ID TAG.
- 13) ENGRAVED STAINLESS STEEL ADDRESS TAG AFFIXED TO WATER METER BOX LID.

	ENVIRONMENTAL UTILITIES DEPARTMENT	
	1 1/2" & 2" RECYCLED WATER SERVICE	
SCALE: NONE REVISED: JANUARY 2021 DRAWN BY: R. VAN NESS APPROVED BY: RICHARD PLECKER		RW-8

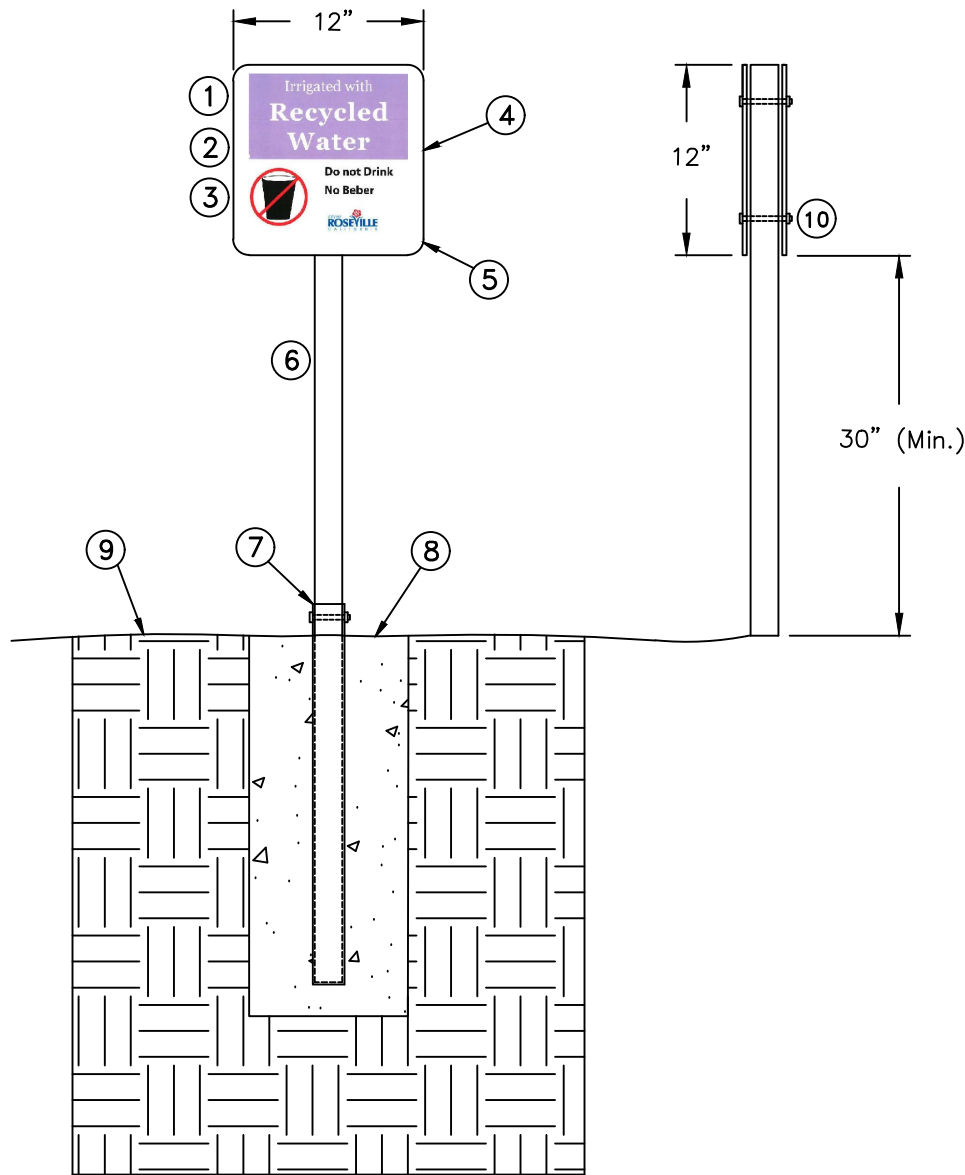

- 1) SIGN: BLANKS TO BE ENGINEER GRADE ALUMINUM SHEETING ALLOY 0.80 GAUGE CORNERS TO HAVE 1" RADIUS ARC. SIGNS TO BE PAINTED AS SHOWN WITH WHITE BACK. TWO SIGNS PER POST.
- 2) THE PURPLE AREA AS SHOWN SHALL BE PER THE FOLLOWING: ALL LETTERS WHITE, FONT TYPE GEORGIA, "Irrigated with" SHALL BE 72 PT AND "Recycled Water" SHALL BE 120 PT. BOLD MATCH CASE.
- 3) INTERNATIONAL "DO NOT DRINK" SYMBOL: BLACK CUP 3" IN HT. SYMBOL WITH RED CIRCLE 3 1/2" DIA. AND SLASH.
- 4) THE BLACK LETTERING AS SHOWN SHALL BE PER THE FOLLOWING: ALL LETTERS BLACK, FONT TYPE ARIAL AND 60 PT. BOLD, MATCH CASE.
- 5) CURRENT APPROVED CITY OF ROSEVILLE LOGO PLACED AS SHOWN.
- 6) 1 3/4" SQUARE PERFORATED STEEL POST POWDER COATED WHITE.
- 7) 2" SQUARE GALV. STEEL ANCHOR SLEEVE MIN. 24" DEEP. SET SLEEVE 2" ABOVE FINISH GRADE AND PROVIDE HOLES FOR THE 5/16" HEX HEAD CAP BOLT.
- 8) 10" DIAMETER BY 24" DEEP CONCRETE FOOTING.
- 9) FINISHED GRADE.
- 10) 5/16" GALV. STL. HEX HEAD CAP BOLTS WITH NUTS
- 11) MOUNTING HARDWARE SHALL NOT OBSTRUCT THE VIEW OF ANY LETTERING LOGOS, OR SYMBOLS.
- 12) RECYCLED WATER SIGNS SHALL BE PROVIDED BY THE CONTRACTOR. SIGNS CAN BE PURCHASED FROM INTERSTATE SALES (530-823-6070) OR ZAP MANUFACTURING (530-272-8855).

Richard D. Plecker

RICHARD PLECKER
ENVIRONMENTAL UTILITIES DIRECTOR



ENVIRONMENTAL UTILITIES
DEPARTMENT

RECYCLED WATER
USE SIGNAGE

SCALE: NONE
REVISED: JANUARY 2021
DRAWN BY: R. VAN NESS
APPROVED BY: RICHARD PLECKER

RW-9

CHRISTY B1730 H/20 RATED UTILITY BOX EQUIV.
 BROOKS OR EQUAL. PROVIDE GALV. STEEL
 CHECKERED PLATE COVER, SCREW DOWN TYPE,
 MARKED "B.O."

NOTE:
 ALL THREADED PIPE
 FITTINGS SHALL BE
 BRASS
 CONCRETE INSTALLED
 FOR STABILITY

VALVE BOX W/LID
 MARKED "B.O."
 INSTALL PER W-16.

11" Ø OD X 4" Ø
 RED. FLANGE X NPT

4" 45 EL

4" NPT TO NSHT NIPPLE

4" NSHT CAP

F.G.

6" MAX.

#4 CONT.

6" DRAIN ROCK

TRACING WIRE

TRANSMISSION
 WATER MAIN

FLANGED
 GATE VALVE

6" Ø FIRE HYDRANT BURY

Richard D. Plecker

RICHARD PLECKER
 ENVIRONMENTAL UTILITIES DIRECTOR

INSULATING FLANGE SEE DETAIL
 W-19, W-20, AND W-21

6" Ø FLANGED DIP AND
 FITTINGS, SEE PLANS
 FOR LENGTH,
 ORIENTATION AND
 LOCATION

	ENVIRONMENTAL UTILITIES DEPARTMENT
	TRANSMISSION MAIN SUBSURFACE BLOW OFF

SCALE: NONE
 REVISED: JANUARY 2023
 DRAWN BY: J. THOMPSON
 APPROVED BY: RICHARD PLECKER

RW-10